

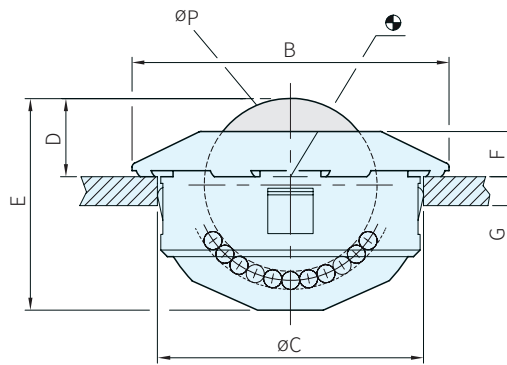

本體		斜面蓋		珠子
材質	處理	材質	處理	材質
鋼	鍍鋅	鋼	鍍鋅	鋼
				SUS



品號	庫存	珠子	P	B	裝配孔 C	D	E	F	G	載重量 (N)	裝配工具	庫存
22750.0104		鋼	15	31	24+0.5	9.5±0.2	20.5	5.5	1.5*	500	22750.0144	
22750.0108	△		22	45	36+0.8	9.8±0.2	28.6	6.0	2.0*	1300	22750.0148	△
22750.0112			30	55	45+1.0	13.8±0.3	37.5	8.0	2.5*	2500	22750.0152	
22750.0124		不銹鋼	15	31	24+0.5	9.5±0.2	20.5	5.5	1.5*	370	22750.0144	
22750.0128	△		22	45	36+0.8	9.8±0.2	28.6	6.0	2.0*	970	22750.0148	△
22750.0132			30	55	45+1.0	13.8±0.3	37.5	8.0	2.5*	1900	22750.0152	

Ps. 備註

- *符號表示鈹材最小厚度
- 1N = 0.101972 kgf

訂貨： 交期：

22750.0104

Ex. 使用例

